



MATERIALS

Steel alloy.

PROTECTION AGAINST CORROSION

Hot dip galvanizing according to CSA-G164 and ASTM A153 Standards.

STANDARDS

All fittings are manufactured according to IEC 61284 Standard.
Fasteners: galvanized steel as per ASTM A325 and ASTM A563 standards.
Forged material: as per EN-10083 equivalent to ASTM A576 standard.
Steel plates: EN-10025 equivalent to ASTM A36 or ASTM A572 standards.
Locking pins: Stainless steel as per AISI 304.

CHAIN LINKS

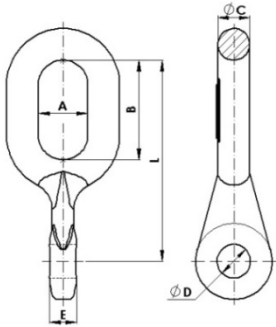

Material: Forged steel EN-10083 equivalent to ASTM A576.
Steel parts finish: Hot dip galvanizing CSA-G164 / ASTM A153.

Reference	Dimensions (inch)						Ultimate Strength (lb)	Weight (lb)
	A	B	C	D	E	L		
ESR-16/AM	1.02	2.05	0.65	11/16	0.57	4.13	28,000	0.99

NOTE: Other dimension "D" can be manufactured upon request.

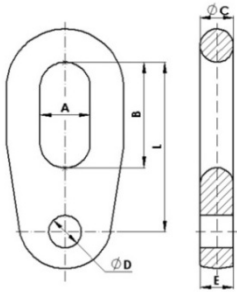

Material: Forged steel EN-10083 equivalent to ASTM A576.
Steel parts finish: Hot dip galvanizing CSA-G164 / ASTM A153.

Reference	Dimensions (inch)						Ultimate Strength (lb)	Weight (lb)
	A	B	C	D	E	L		
ESP-16/AM	1.06	2.24	0.71	11/16	0.71	3.58	30,000	1.39
ESP-20/AM	1.06	2.24	0.71	13/16	0.71	3.39	48,000	1.37

NOTE: Other dimension "D" can be manufactured upon request.

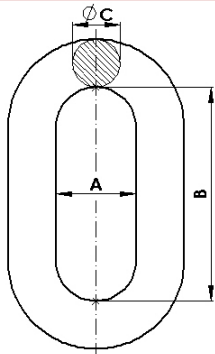

Material: Forged steel EN-10083 equivalent to ASTM A576.
Steel parts finish: Hot dip galvanizing CSA-G164 / ASTM A153.

Reference	Dimensions (inch)			Ultimate Strength (lb)	Weight (lb)
	A	B	C		
ES-16/20/AM	1.18	3.15	0.71	54,000	1.10
ES-36/AM	1.18	3.46	0.87	80,000	1.83
ES-50/AM	1.42	4.33	1.02	110,000	3.15



DOUBLE EYES

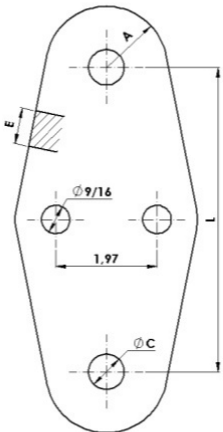

Material: Steel plate EN-10025 equivalent to ASTM A36 or ASTM A572.
Steel Parts finish: Hot dip galvanizing CSA-G164 / ASTM A153.

Reference	Dimensions (inch)				Ultimate Strength (lb)	Weight (lb)
	A	C	E	L		
ENP-16-P/AM	1.18	11/16	0.71	5.91	28,000	4.14
ENP-20-P/AM	1.18	13/16	0.79	5.91	48,000	4.56
ENP-30-P/AM	1.38	15/16	0.87	5.91	62,000	5.56

NOTE: Other dimension "C" can be manufactured upon request.

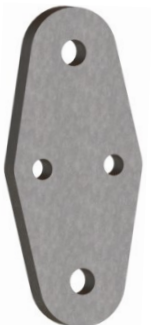

TWISTED CONNECTORS

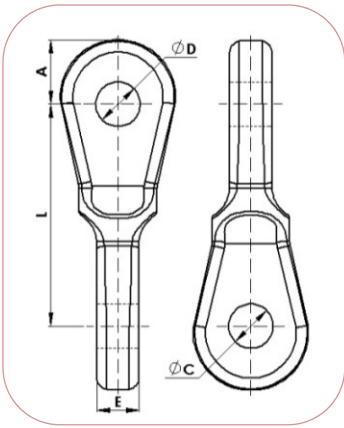

Material: Forged steel EN-10083 equivalent to ASTM A576.
Steel parts finish: Hot dip galvanizing CSA-G164 / ASTM A153.

Reference	Dimensions (inch)					Ultimate Strength (lb)	Weight (lb)
	A	C	D	E	L		
LC-150/AM	1.14	11/16	11/16	0.75	3.94	34,000	1.92
LC-300/AM	1.14	15/16	15/16	0.75	3.94	68,000	1.79

NOTE: Other dimensions "C" and "D" can be manufactured upon request.



BALL EYES

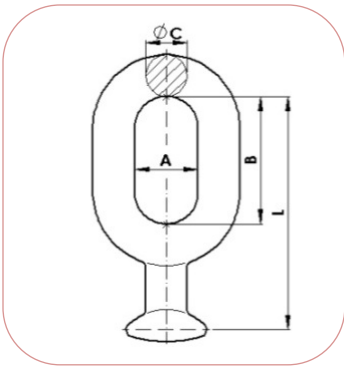

Material: Forged steel EN-10083 equivalent to ASTM A576.
Steel parts finish: Hot dip galvanizing CSA-G164 / ASTM A153.

Reference	Standard	Dimensions (inch)				Ultimate Strength (lb)	Weight (lb)
		A	B	C	L		
AB-5/AM	ANSI 52-5	1.02	2.05	0.73	3.56	28,000	1.12



BALL EYES FOR ARCING HORNS

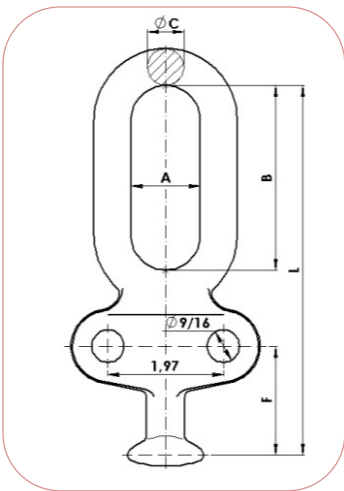

Material: Forged steel EN-10083 equivalent to ASTM A576.
Steel parts finish: Hot dip galvanizing CSA-G164 / ASTM A153.

Reference	Standard	Dimensions (inch)					Ultimate Strength (lb)	Weight (lb)
		A	B	C	F	L		
AB-8-P/AM	ANSI 52-8	1.57	3.15	0.79	2.36	6.81	40,000	2.62

