



## MATERIALS

Steel alloy.

## PROTECTION AGAINST CORROSION

Hot dip galvanizing according to CSA-G164 and ASTM A153 Standards.

## STANDARDS

All fittings are manufactured according to IEC 61284 Standard.  
Fasteners: galvanized steel as per ASTM A325 and ASTM A563 standards.  
Forged material: as per EN-10083 equivalent to ASTM A576 standard.  
Locking pins: Stainless steel as per AISI 304.

## SOCKET EYES

**Material:** Forged steel EN-10083 equivalent to ASTM A576.  
**Steel parts finish:** Hot dip galvanizing CSA-G164 / ASTM A153.

**Locking pins:** Stainless steel.

Reference	Standard	Dimensions (inch)			Ultimate Strength (lb)	Weight (lb)
		D	E	L		
R-5/16/AM	ANSI 52-5	11/16	0.63	2.01	28,000	1.17
R-5/21/AM	ANSI 52-5	11/16	0.83	2.01	28,000	1.26
R-5/26/AM	ANSI 52-5	11/16	1.02	2.01	28,000	1.39
R-5/36/AM	ANSI 52-5	11/16	1.42	2.01	28,000	1.52
R-5/45/AM	ANSI 52-5	11/16	1.77	2.01	28,000	1.63
R-8/16/AM	ANSI 52-8	13/16	0.63	3.35	40,000	-
R-8/21/AM	ANSI 52-8	13/16	0.83	3.35	40,000	-
R-8/26/AM	ANSI 52-8	13/16	1.02	3.35	40,000	-
R-8/36/AM	ANSI 52-8	13/16	1.42	3.35	40,000	-
R-8/45/AM	ANSI 52-8	13/16	1.77	3.35	40,000	-
R-8/16/22/AM	ANSI 52-11	7/8	0.63	3.35	50,000	-
R-8/21/22/AM	ANSI 52-11	7/8	0.83	3.35	50,000	-
R-8/26/22/AM	ANSI 52-11	7/8	1.02	3.35	50,000	-
R-8/36/22/AM	ANSI 52-11	7/8	1.42	3.35	50,000	-
R-8/45/22/AM	ANSI 52-11	7/8	1.77	3.35	50,000	-

NOTE: Other dimensions "E" and "D" can be manufactured upon request..

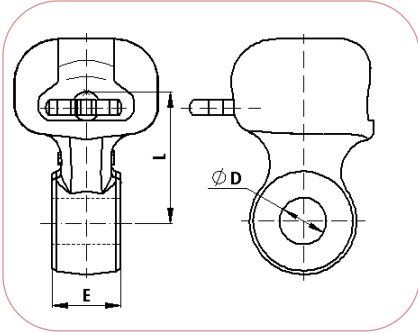

## LONG SOCKET EYES

**Material:** Forged steel EN-10083 equivalent to ASTM A576.  
**Steel parts finish:** Hot dip galvanizing CSA-G164 / ASTM A153.

**Locking pins:** Stainless steel.

Reference	Standard	Dimensions (inch)					Ultimate Strength (lb)	Weight (lb)
		C	D	E	F	L		
R-5-L/18/AM	ANSI 52-5	0.89	11/16	0.71	5.91	10.00	30,000	3.44
R-5-L/24/AM	ANSI 52-5	0.89	11/16	0.94	5.91	10.00	30,000	3.57
R-5-L/36/AM	ANSI 52-5	0.89	11/16	1.42	5.91	10.00	30,000	3.79

NOTE: Other dimensions "E" and "D" can be manufactured upon request.

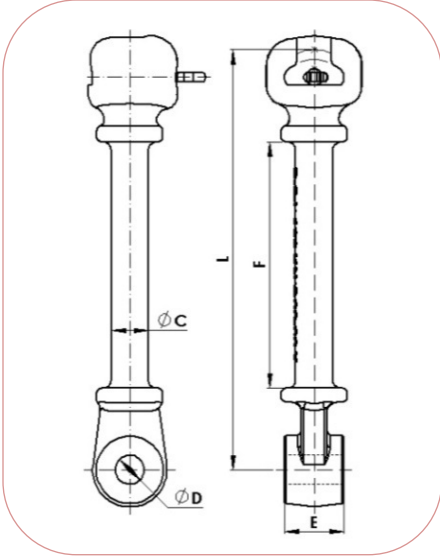

# CLEVIS SOCKETS

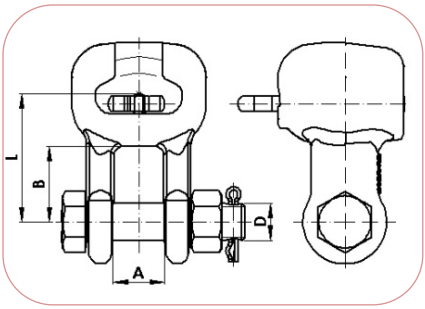

**Material:** Forged steel EN-10083 equivalent to ASTM A576.  
**Steel parts finish:** Hot dip galvanizing CSA-G164 / ASTM A153.  
**Locking pins:** Stainless steel.

**Bolt:** ASTM A325.  
**Nut:** ASTM A563.

Reference	Standard	Dimensions (inch)				Ultimate Strength (lb)	Weight (lb)
		A	B	D	L		
RH-5/AM	ANSI 52-5	0.98	1.18	5/8	1.97	28,000	1.65

NOTE: Special fasteners upon request.

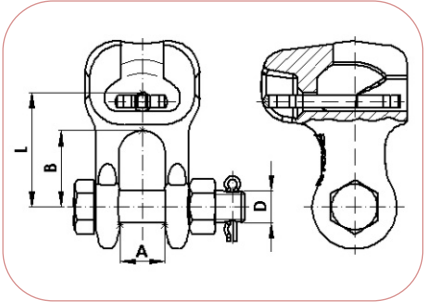

**Material:** Forged steel EN-10083 equivalent to ASTM A576.  
**Steel parts finish:** Hot dip galvanizing CSA-G164 / ASTM A153.  
**Locking pins:** Stainless steel.

**Bolt:** ASTM A325.  
**Nut:** ASTM A563.

Reference	Standard I.E.C./ANSI	Dimensions (inch)				Ultimate Strength (lb)	Weight (lb)
		A	B	D	L		
RH-8-AE/AM	ANSI 52-8	1.02	1.69	3/4	2.64	40,000	3.77
RH-8-AE/22/AM	ANSI 52-11	1.02	1.69	3/4	2.64	50,000	3.77

NOTE: Special fasteners upon request.

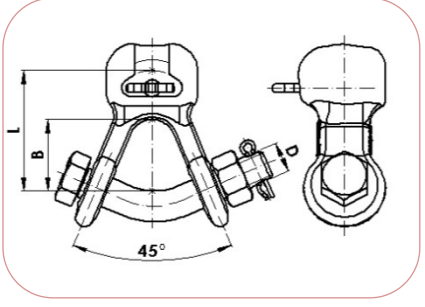

**Material:** Forged steel EN-10083 equivalent to ASTM A576.  
**Steel parts finish:** Hot dip galvanizing CSA-G164 / ASTM A153.  
**Locking pins:** Stainless steel.

**Bolt:** ASTM A325.  
**Nut:** ASTM A563.

Reference	Standard	Dimensions (inch)			Ultimate Strength (lb)	Weight (lb)
		B	D	L		
RHV-5/AM	ANSI 52-5	1.65	3/4	2.68	28,000	2.43

NOTE: Special fasteners upon request.



# LONG CLEVIS SOCKETS

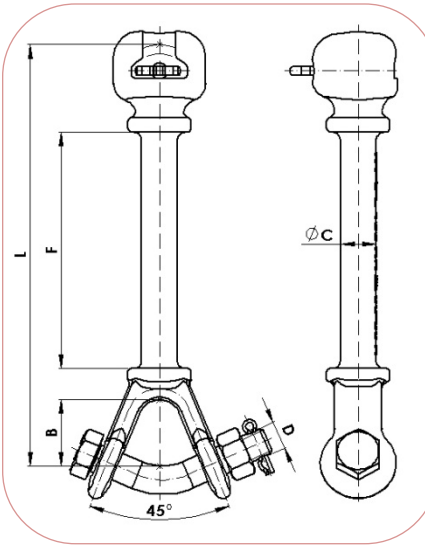

**Material:** Forged steel EN-10083 equivalent to ASTM A576.  
**Steel parts finish:** Hot dip galvanizing CSA-G164 / ASTM A153.  
**Locking pins:** Stainless steel.

**Bolt:** ASTM A325.  
**Nut:** ASTM A563.

Reference	Standard I.E.C./ANSI	Dimensions (inch)					Ultimate Strength (lb)	Weight (lb)
		B	C	D	F	L		
RV-5-L/AM	ANSI 52-5	1.59	0.89	3/4	5.91	10.24	30,000	4.41
RV-8-L/AM	ANSI 52-8	1.61	0.89	3/4	5.91	10.75	50,000	6.57

NOTE: Special fasteners upon request.

